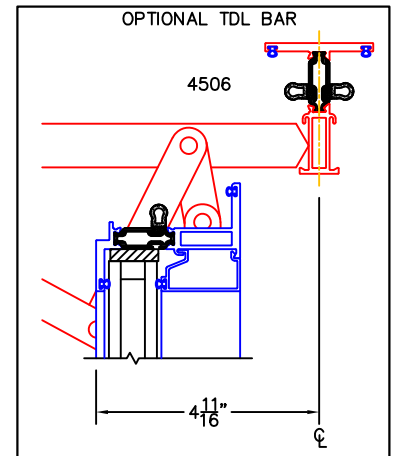
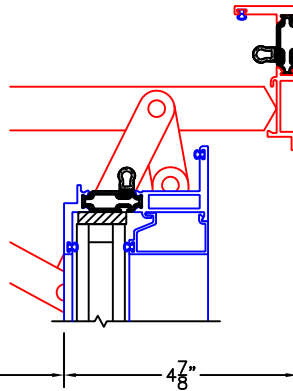
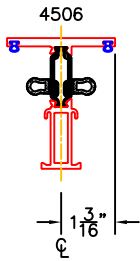
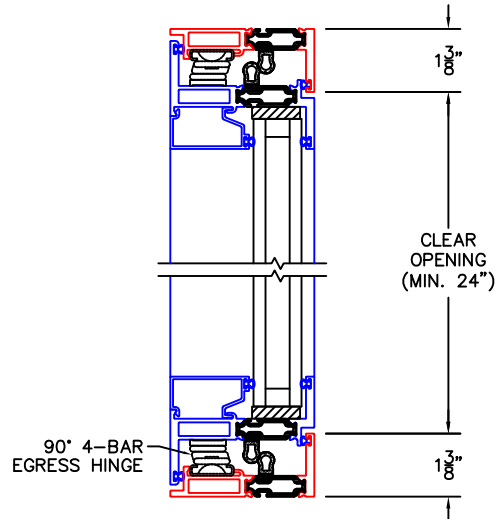
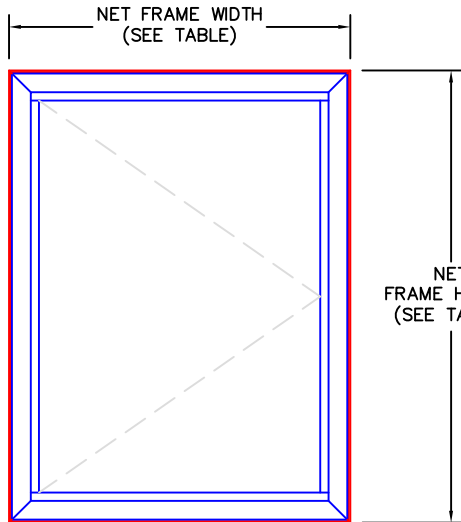

(USE RULER TO SCALE DIMENSIONS IN INCHES)

**SCALE: 1/4"**

## CASEMENT WINDOW (EGRESS DETAILS)

 HARDWARE: -4-BAR EGRESS HINGES  
 -CAM HANDLES

### EGRESS REQUIREMENTS:

1. MINIMUM NET CLEAR OPENING WIDTH SHALL BE 20"
2. MINIMUM NET CLEAR OPENING HEIGHT SHALL BE 24"
3. MINIMUM NET CLEAR OPENING MUST BE GREATER THAN 5.7 SQ.FT.

### SERIES 450-T CASEMENT EGRESS DIMENSIONS

NET FRAME WIDTH	NET FRAME HEIGHT(MIN.)	CLEARANCE WIDTH	CLEARANCE HEIGHT	CLEAR OPENING SQ.FT.
26.25	43.875	20.00	41.063	5.70
27.25	41.875	21.00	39.125	5.71
28.25	40.063	22.00	37.313	5.70
29.25	38.438	23.00	35.688	5.70
31.25	35.625	25.00	32.875	5.71
33.25	33.25	27.00	30.438	5.71

NET FRAME HEIGHT OF CASEMENT WINDOWS SHALL NOT BE LESS THAN THE NET FRAME WIDTH. USING THIS RULE, WINDOWS WITH A NET FRAME WIDTH GREATER THAN 33.25", WILL MEET EGRESS.